

# Home Owners Information and Warranty.

## BSC & MSC Series



**Please Send Warranty Activation to  
activate@powerz-on or Fax: 011 965-0187**

## ***Contents:***

Page:

2. Contents.
3. Systems - Close Coupled Thermosiphon Direct
4. Systems - Close Coupled Thermosiphon Indirect
4. Systems - Split Thermosiphon
5. Systems - Split Pumped
6. Collector Piping Configuration
7. Maintenance
8. Warranty
8. Safety
9. Emergency & Shutdown Procedures
10. Warranty Claim Procedure
10. Information for the Home Owner
11. System Description
12. Warranty Activation Form.

### **Congratulations on choosing a Powerz-On Product.**

At Powerz-On, we are passionate about reducing carbon emissions, decreasing dependancy on fossil fuels and helping to build a healthier future for our planet. Our solutions are locally manufactured and tailored specifically for South Africa to ensure that they are relevant to our market, deliver value for money and make a positive contribution to our country, its communities and its people.

## Powerz-On Close Coupled Thermosiphon Direct

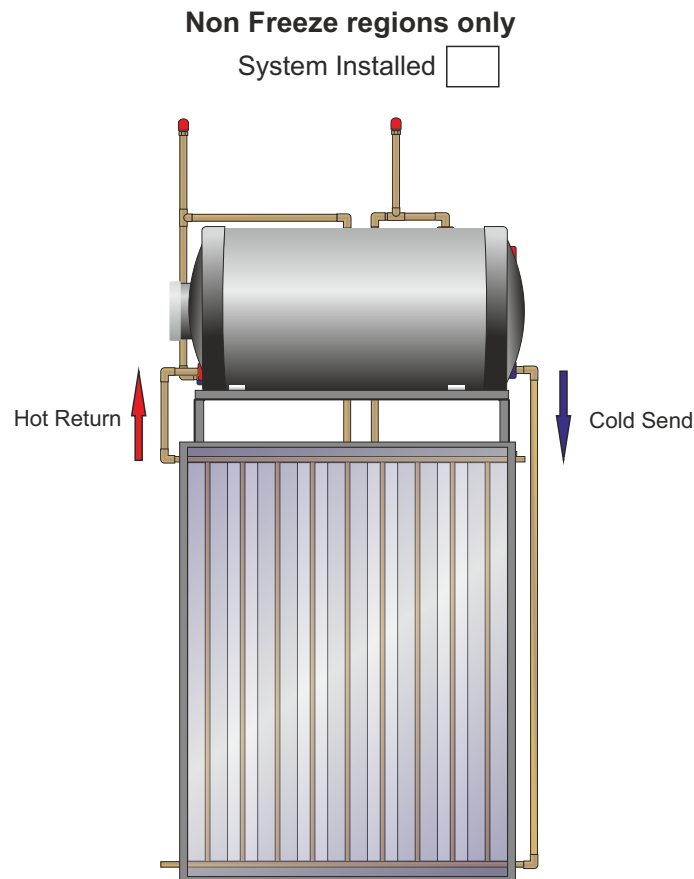

### Description:

Thermosiphon is a natural process. In this process, just like air, hotter water naturally rises to the top of a vessel, whilst the colder water naturally descends to the lower part of the same vessel. No electrical or mechanical assistance is required for this process to occur, the sun's energy which heats the water in the collector will cause the thermosiphon flow, which in turn heats the geyser.

In the close coupled Thermosiphon Direct system the Collector and Geyser are installed outside on the roof of the house, as close to each other as possible, with the geyser being mounted above the solar collector. this is required for the thermosiphon process to occur.

The close coupled Thermosiphon Direct system uses the potable water in the geyser as the heat transfer medium, meaning the water in the geyser flows through the solar collector heating up and returning to the geyser.

A Direct system is not suitable for regions where Frost occurs. As a result the system is recommended for Coastal and non freeze regions only.

 **For Full Installation Instructions go to [www.powerz-on.co.za](http://www.powerz-on.co.za)**

# Powerz-On Close Coupled Thermosiphon Indirect Systems

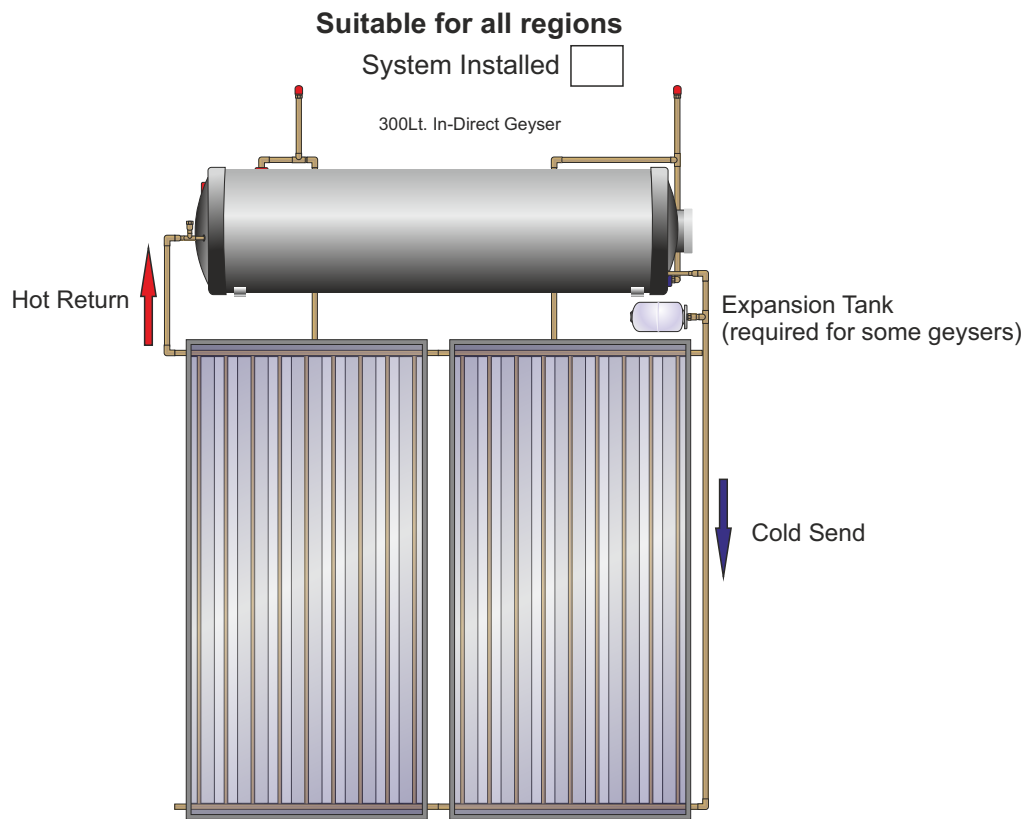

## Description:

In this system, the solar Geyser is mounted on the roof.

The Close Coupled Thermosiphon Indirect Systems rely on the same natural Thermosiphon process. The difference however, is that unlike the Direct System, the Indirect System uses a Heat Transfer Fluid instead of water in the Solar Collector, this fluid is called Propylene Glycol.

Propylene Glycol is a non poisonous Antifreeze liquid.

As before, the Geyser and Solar Collector are installed outside on the roof of the house, with the geyser being mounted above the solar collector. This is required for the thermosiphon process to occur.

In the Indirect system, Propylene Glycol circulates through the collector, heats up, and flows into the Heat Exchange System of the geyser. The Heat Exchange is an enclosed system, the water in the geyser and the glycol do not mix at anytime.

Indirect Systems are fully frost resistant, and can be used in all regions of South Africa.



**For Full Installation Instructions go to [www.powerz-on.co.za](http://www.powerz-on.co.za)**

# Powerz-On Split Thermosiphon Direct & Indirect Systems

Freeze protection is heat transfer system dependant.

## Description:

System Installed

In this system, the Solar Geyser is mounted in the Roof.

Split Thermosiphon Systems still rely on the natural process of thermosiphon. For Thermosiphon flow to heat the Geyser, the Geyser must be above the Solar Collector.

In this type of application, the angle of the roof must be sufficient for the Geyser to be mounted inside the roof, with the Solar Collector mounted outside the roof, but below the lowest point of the Geyser.

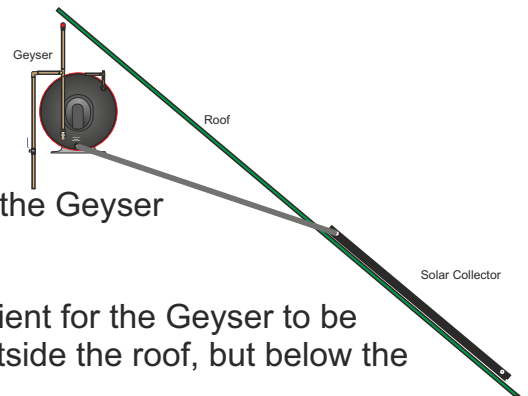

Split Thermosiphon Installations can be applied to both Direct and Indirect Systems. An Indirect system must be used in areas where Frost occurs.

This type of system application is especially useful in areas where aesthetics is vital, as all that will be visible of the system is the Solar Collector mounted neatly on the roof.

As in the other Thermosiphon systems, there is a back up Electrical heating element, which provides the home owner with additional hot water if needed.

# Powerz-On Split Pumped Systems

Freeze Resistant - Electrical Supply or Heat Transfer dependant.

## Description:

System Installed

Split Pumped Systems do not rely on Thermosiphon, but rather employ a Pump to force the flow of water. A system controller is used to monitor the temperature in the Geyser and in the Solar Collector, when the Solar Collector is hotter than the geyser, the pump is activated, transferring the heat from the Solar Collector to the geyser.

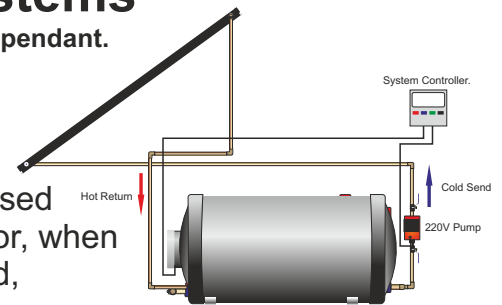

The System Controller is able to activate the electrical heating element if required, and has a form of Frost protection. The Controller is reliant on electricity, and as a result, if there is a cut in power at the same time as frost occurs, there could be damage to the Solar Collector. If a Direct System is installed in a frost area, we recommend adding a UPS as back-up electricity to protect the system.

In the Split Pumped System, the Geyser is kept in place in the roof, with the pump and controller added. All that is visible outside is the Solar Collector mounted on the roof, making this system ideal for housing complexes, and other areas where aesthetics is important.

Split Pumped Systems can be installed as Direct or Indirect Systems, this is Geyser dependant.

 **For Full Installation Instructions go to [www.powerz-on.co.za](http://www.powerz-on.co.za)**

## Powerz-On Collector Piping Configuration

### W-Series Collector

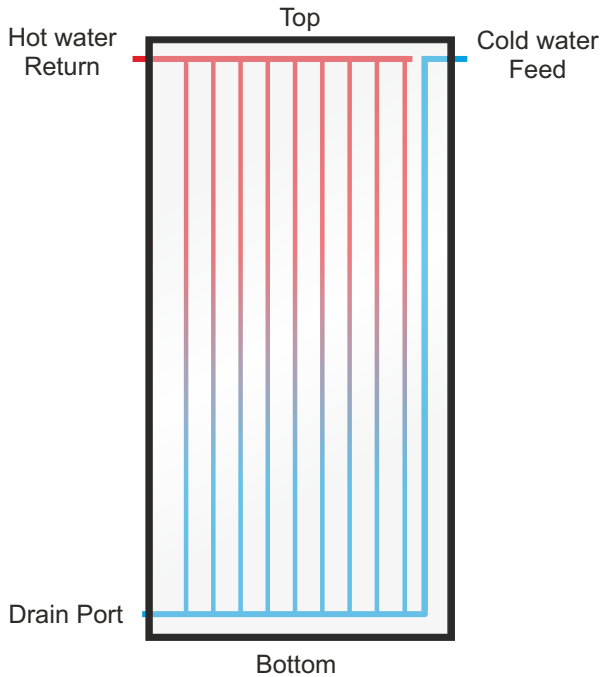

### ST-Series Collector

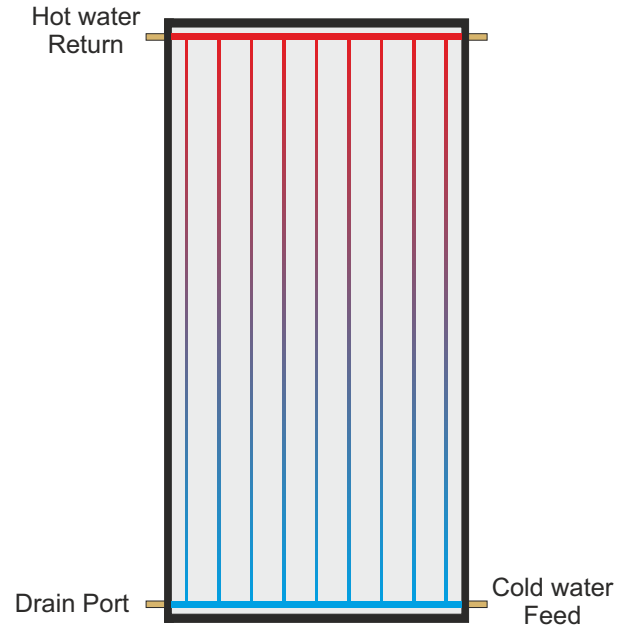

### Twin Collector

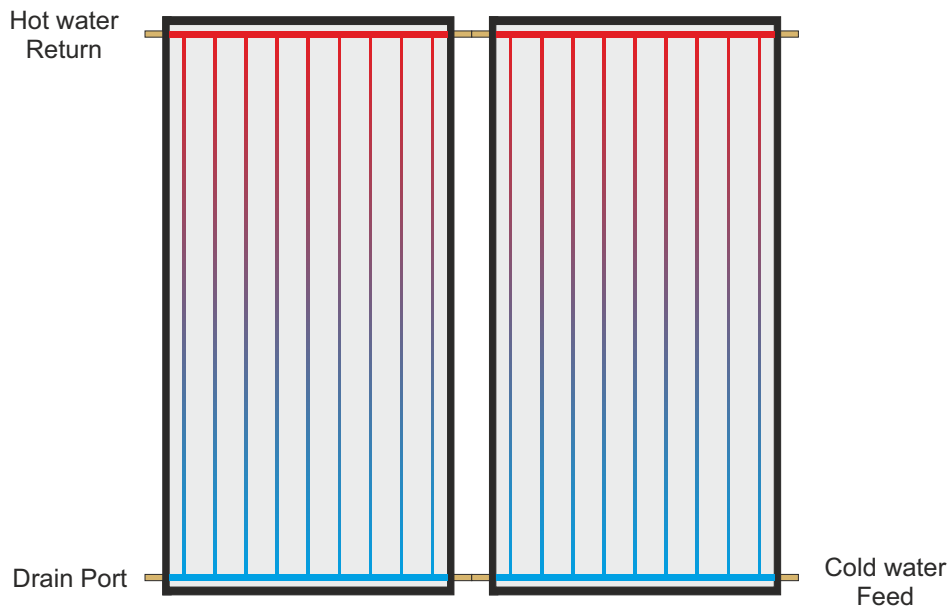

For Full Installation Instructions go to [www.powerz-on.co.za](http://www.powerz-on.co.za)

## Maintenance:

1. If at any time you suspect a leak or problem with the system please follow Emergency Shut Down procedure, and call your Installer immediately.
2. Inland Areas: The Solar Collector should be kept free from dust or pollen at all times.
3. Coastal Areas: The Solar Collector should be kept free from salt crystallisation.
3. Indirect Solar Systems: The Propylene Glycol (Anti-Freeze) will degrade over time. The Solar Water Heating System will need to be drained and refilled every (3) three years.
4. The entire system should be checked Annually for any leaks or problems. If you suspect a problem, the Installer should be contacted immediately.
5. Powerz-On recommend the thermostat in the Geyser be set to 55°C.
6. Never allow trees, shrubs or other large obstacles to cast a shadow on the solar collector. Please check during summer and winter.
7. Winter Time:
  - 7.1 The Dump Valve (Back-up frost protection) must be checked every 6 months or Before the start of Winter.
  - 7.2 Active Systems: Make sure the Frost protection system is activated, and a UPS system is installed, and functioning correctly.
  - 7.3 Make sure all piping is insulated.

### Away Periods

1. In summer, hot water is not going to be used for weeks, it is advisable to cover the Solar Collector(s) with a canvas or an old blanket (NOT WITH BLACK PVC!). This will prevent the system from over-heating.
2. The Geyser Wise Max should be set to Holiday Mode.

### Once a Year

The temperature and pressure valve(s) should be checked for proper operation. **This should be done by an Accredited Technician.**

**NB.: It is also recommended that an Authorised Powerz-On Installer performs a full system check-up In accordance with SANS 10106 once a year. This will allow the system to perform at its optimum.**



## ***Powerz-On Warranty***

Powerz-On gives the buyer the assurance that all components of the Solar System supplied by Powerz-On have been tested both as individual components and as a part of an integrated system. The system complies with all the relevant SANS requirements and carries the SABS mark of Approval.

**Please Note:**

1. All installations must be carried out by, and signed off by a Powerz-On accredited Installer. Failure to do so will render the Warranty Null and Void.
2. All installations must comply with SANS 10106.
3. The Powerz-On Warranty applies to the Powerz-On Collector only, all other components supplied by, but forming part of the system, but not manufactured by Powerz-On carry their own Warranty provided by their respective Manufacturers.

### ***Warranty:***

The Powerz-On Solar Collector comes with a comprehensive one (1) year parts and labour warranty and guarantee to replace the Solar Collector if the Collector fails within ten (10) Years.

### ***10 Year Replacement Guarantee:***

Powerz-On will provide a free replacement Solar Collector from it's nearest branch office or approved agent. Under this replacement guarantee, the transport, installation and labour costs of delivering the replacement Solar Collector and removing the existing Solar Collector and installing the replacement Collector, will be for the account of the owner of the existing Solar Water Heater.

Where a Solar Collector or a component of the solar system is replaced, the balance of any original Warranty or Replacement Guarantee period will remain effective. The replacement Solar Water Heater or part does not carry any additional warranty or replacement Guarantee.

The period of Warranty is from date of Installation providing the documented proof of Installation and sale is furnished, or alternatively from date of manufacturer as determined from the serial plate code on the Solar Collector. The following conditions apply.:

1. The Warranty only applies to defects, which have arisen solely due to faulty materials or workmanship during the manufacturing process of the Solar Collector.
2. The Solar Collector Glass is not covered by the Warranty. Manufacturers Defects Excluded.
3. Any Freeze damage caused as a result of the Solar Collector being installed as a direct system in frost areas, is not covered by the Warranty.



4. Frost protection in the Pumped Direct system is dependant on an electrical supply. Any frost damage resulting from loss of, or intermittent Electrical supply, is not covered by the warranty.
5. Any damage caused to the Solar Collector due to propylene glycol not being used, or the propylene glycol failing in the Indirect System, is not covered by the Warranty.
6. Any damage caused to the Solar Collector due to improper installation, or modifications made to the Solar Collector, is not covered by the Warranty.
7. Any damage caused due to an act of nature, is not covered by the Warranty.
8. Any damage caused due to Collector over heating is not covered by the Warranty.  
Note: If Collector temperature exceeds 100°C, permanent damage can occur.
9. Any damage caused to the Solar System due to water quality being outside the chemical parameters stated below, is not covered by the Warranty.:

PH	6.5-8.5
Total dissolved solids	600 mg/L
Calcium coronate level (Hardness)	200 mg/L
Chlorides	250 mg/L
Magnesium	10 mg/L

The Warranty on the Installation is the responsibility of the Installer. The System must be installed in compliance with SANS 10106.

### **Safety:**

1. Do not tamper with any part of the installation.
2. Do not touch the Hot supply pipe from the Solar Collector/s, as this pipe can get extremely hot.
3. The Draining and Replacing of the heat transfer fluid (Glycol) must be carried out every three (3) years, and must be done by an authorized Powerz-On Installer.

### **Emergency and Shutdown Procedures:**

In the event of a problem arising with the Solar Water Heater, the following procedure should be follower.

1. Switch off the Geyser at the electrical distribution board (DB board).
2. If there is any evidence of a water leak from any part of the system, shut off the water supply to the Solar Water Heater, at the shutoff valve before the Solar Water Heater, or at the mains water supply.
3. If there is any evidence of a heat transfer fluid leak (Glycol) in any part of the system, try and capture the leaking fluid into a bucket or container. Keep the container for inspection by the Installer.
4. Contact the company that installed the Solar Water Heater, or an authorised Solar Water Heater Installer.

## ***Warranty Claim Procedure***

Powerz-On Solar Collectors are Manufactured in South Africa, and are manufactured to the highest standard. That said, there are times when circumstances that are beyond Powerz-On's control will result in product failure. In this instance please follow the process below.

1. Please follow the Emergency shut down procedure, to prevent any damage to the system or property.
2. Contact the Installer immediately. The installer should be able to resolve any system failure. If the Installer is unable to provide a suitable resolution please contact Powerz-On Solar Systems.
3. Complete an Incident report form. This form is available from the Powerz-On offices, or at [www.powerz-on.co.za](http://www.powerz-on.co.za).
4. Mail the completed Incident report form to [info@powerz-on.co.za](mailto:info@powerz-on.co.za). Alternatively contact Powerz-On Solar Systems directly. We will make every effort to assist you.

Disputes:

Should a complaint not be resolved satisfactorily, the SESSA Ombudsman can be contacted on: [ombudsman@sessa.org.za](mailto:ombudsman@sessa.org.za)

## **Information for the Home Owner**

(to be completed by the Installer upon completion of the Installation)

**Installer Information:**

Installer Name: \_\_\_\_\_

Company Name: \_\_\_\_\_

Physical Address: \_\_\_\_\_

\_\_\_\_\_

Tel (office): \_\_\_\_\_

Cell (emergency): \_\_\_\_\_

E-Mail: \_\_\_\_\_

**System Description:**

Geyser manufacturer: \_\_\_\_\_

System	Split or Close Coupled		Circulation Method		Tick Appropriate Block
Direct	Split		Pumped		
	Split		Thermosiphon		
	Close Coupled		Thermosiphon		
Indirect	Split		Pumped		
	Split		Thermosiphon		
	Close Coupled		Thermosiphon		
Tank Size:	100Lt.	150Lt.	200Lt.	250Lt.	300Lt.
Tick Block					
Collector:	ST-150	ST-200	ST-300	ST-2.2	ST-2.5
Tick Block					

**Installation Date:** \_\_\_\_\_

**Collector.**

Serial Number: 1. \_\_\_\_\_ 2. \_\_\_\_\_

**Geyser.**

Serial Number: 1. \_\_\_\_\_ 2. \_\_\_\_\_

## Warranty Activation Form

Please Note: The warranty comes into force when the activation has been registered with Powerz-On Solar Systems. This is the responsibility of the owner of the solar system.

Please E-mail to [activate@powerz-on.co.za](mailto:activate@powerz-on.co.za) or Fax to 011 965-0187

**Home Owners Details:** (to be completed by the Home Owner)

Name: \_\_\_\_\_

Physical Address: \_\_\_\_\_

Tel (Home): \_\_\_\_\_ Tel (office): \_\_\_\_\_

Cell : \_\_\_\_\_ E-Mail: \_\_\_\_\_

**Installer Information:** (to be completed by the Installer)

Name: \_\_\_\_\_

Company Name: \_\_\_\_\_

Physical Address: \_\_\_\_\_

Tel (office): \_\_\_\_\_ Cell: \_\_\_\_\_

E-Mail: \_\_\_\_\_

**Declaration:**

Powerz-On Authorized Installer Certificate No.: \_\_\_\_\_

I, the above-mentioned Powerz-On Authorized Solar Water Heater installer, confirm that the solar water heater and/or Solar Collector installation carried out by myself, complies with Powerz-On requirements and SANS 10106 Installation Specifications.

\_\_\_\_\_  
Signature:

\_\_\_\_\_  
Date:

**System Description:**

(to be completed by the Installer)

Geyser manufacturer: \_\_\_\_\_

System	Split or Close Coupled		Circulation Method		Tick Appropriate Block
Direct	Split		Pumped		
	Split		Thermosiphon		
	Close Coupled		Thermosiphon		
Indirect	Split		Pumped		
	Split		Thermosiphon		
	Close Coupled		Thermosiphon		
Tank Size:	100Lt.	150Lt.	200Lt.	250Lt.	300Lt.
Tick Block					
Collector:	ST-150	ST-200	ST-300	ST-2.2	ST-2.5
Tick Block					

**Installation Date:** \_\_\_\_\_

**Collector.**

Serial Number: 1. \_\_\_\_\_ 2. \_\_\_\_\_

**Geyser.**

Serial Number: 1. \_\_\_\_\_ 2. \_\_\_\_\_



**Tel: +27 10 003 0127**

**Fax: +27 11 965-0187**

**E-Mail: [info@powerz-on.co.za](mailto:info@powerz-on.co.za)**

**Web: [www.powerz-on.co.za](http://www.powerz-on.co.za)**

**Warranty Activation: [activate@powerz-on.co.za](mailto:activate@powerz-on.co.za)**

**Address: Cnr. Botha and Pretoria Rd. Petit,  
Benoni, 1501  
Gauteng, South Africa.**

**GPS: S26°6.235 E28°22.229**